

RENNA™ 450

Side Adjust Series Roller

ASSA ABLOY

assaabloy.com

Experience a safer
and more open world

ASSA ABLOY's RENNA™ series offers the latest innovation in high quality sliding door rollers. Featuring Interlock USA's patented interlocking technology, RENNA™ rollers are AAMA certified to effortlessly move the heaviest door panels without collapse or separation.



Standard

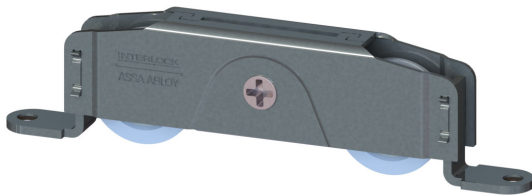

Extended



Inverted



Snap-In

The RENNA™ 450 Side Adjust series rollers, adjustable at full load, are offered in various configurations to suit your sliding door requirements. Extruded, turned composite wheels provide quiet operation and reduced track wear.

Features

- Patented interlocking technology prevents collapse and separation at maximum load
- Precision wheel bearings with rubber end seals
- Industry leading carriage wall thickness
- Offered with extruded, turned composite wheels for smoother operation
- Adjustment screw accessible at both sides
- Certified to the requirements of AAMA 906-21
- Weight capacity 450 lbs per pair at 10000 cycles per AAMA 906-21
- Available for use on vinyl, wood and aluminum

Specifications:

Roller diameter: 1.25"

Maximum door weight: 450 lbs*

Adjustment range: Standard, Inverted & Snap In: 0.36" Extended: 0.26"

*Capable of supporting over 625 lbs with reduced operating cycles

www.interlockna.com
877.852.8808

INTERLOCK™
ASSA ABLOY

RENNA™ 450

Standard Mounting Tabs

ASSA ABLOY

assaabloy.com

Experience a safer
and more open world



Standard

Part Code	Case & Carrier Material	Wheel Material	Adjustment Range	Box Quantity
PR05-6000	Stainless	Stainless	0.36"	40
PR05-6005	Stainless	Plastic	0.36"	40
PR05-6100	Steel	Steel	0.36"	40
PR05-6105	Steel	Plastic	0.36"	40
PR05-6106	Steel	Composite	0.36"	40
PR05-6107	Stainless	Composite	0.36"	40

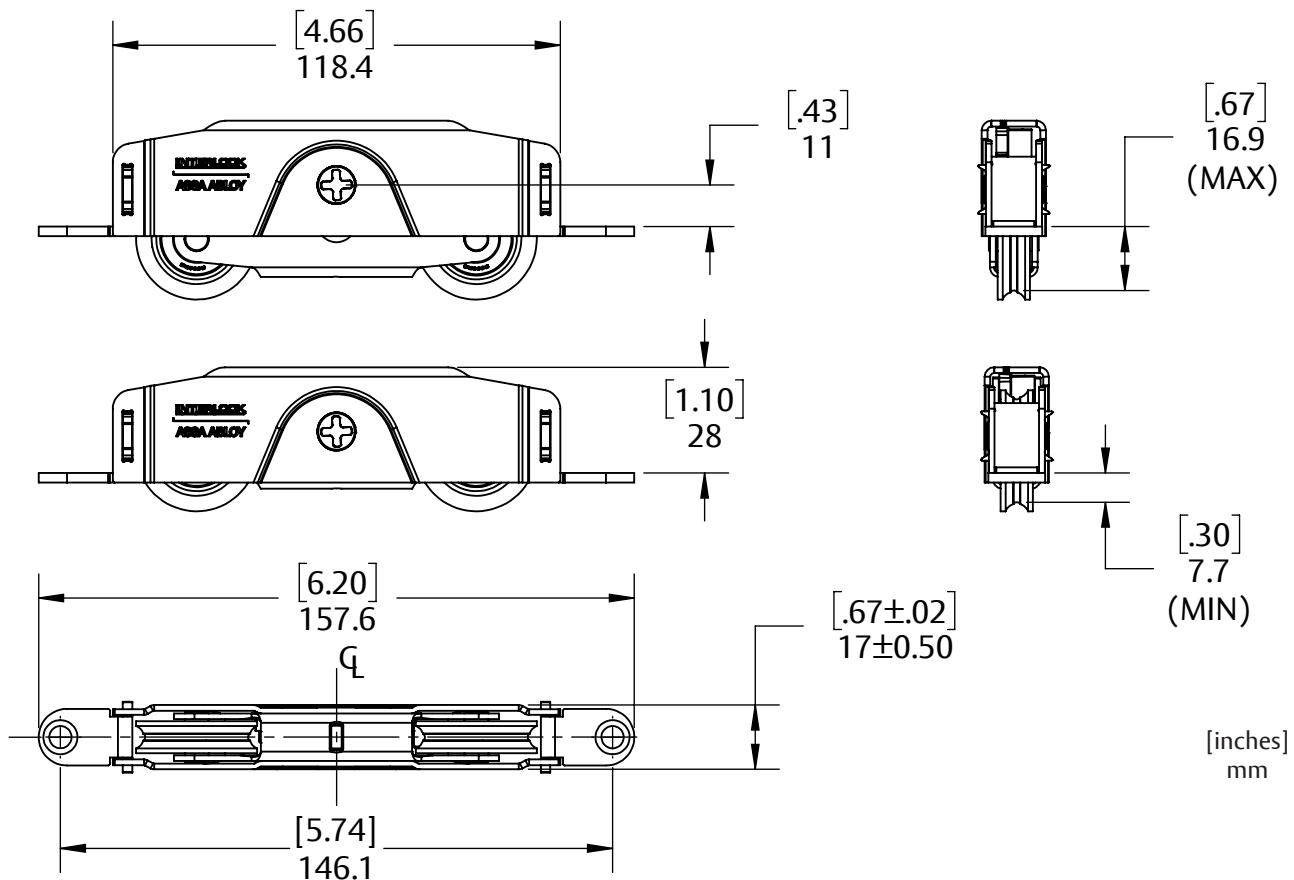

www.interlockna.com
877.852.8808

INTERLOCK™
ASSA ABLOY

RENNA™ 450

Extended Mounting Tabs

ASSA ABLOY

assaabloy.com

Experience a safer
and more open world



Extended

Part Code	Case & Carrier Material	Wheel Material	Adjustment Range	Box Quantity
PR05-6120	Steel	Steel	0.26"	40
PR05-6122	Stainless	Stainless	0.26"	40
PR05-6125	Steel	Plastic	0.26"	40
PR05-6126	Steel	Composite	0.26"	40

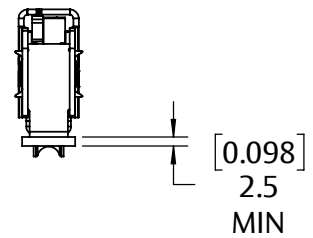
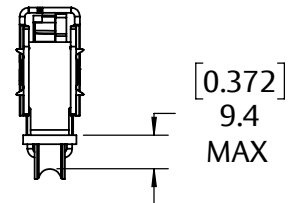
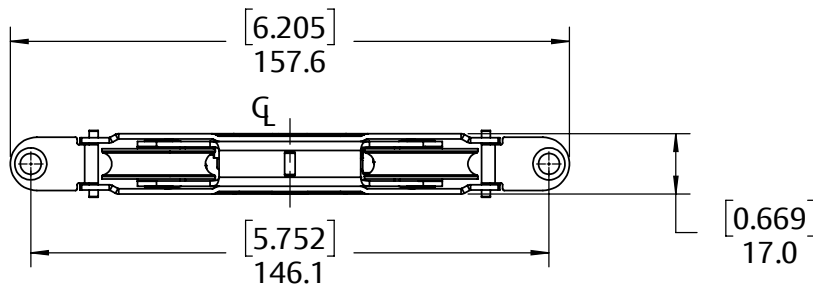
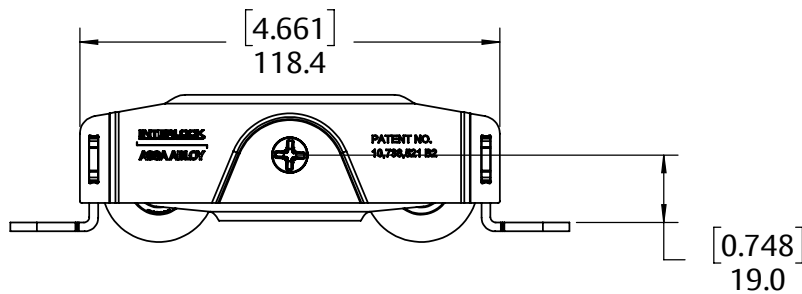
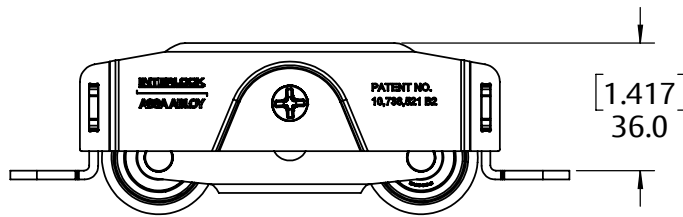

[inches]
mm

RENNA™ 450

Inverted Mounting Tabs

ASSA ABLOY

assaabloy.com

Experience a safer
and more open world



Inverted

Part Code	Case & Carrier Material	Wheel Material	Adjustment Range	Box Quantity
PR05-6007	Stainless	Plastic	0.36"	40
PR05-6008	Stainless	Stainless	0.36"	40
PR05-6108	Steel	Steel	0.36"	40

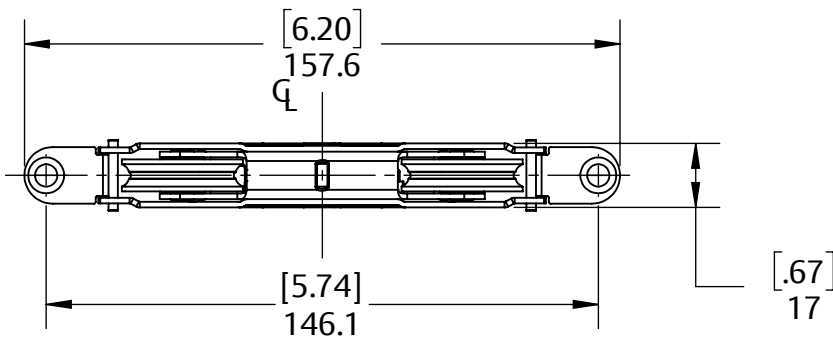
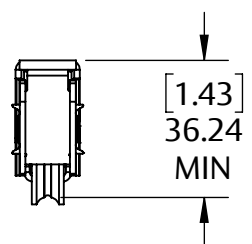
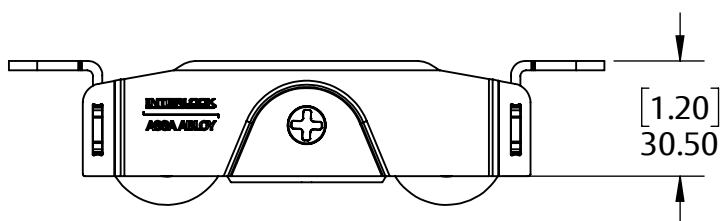
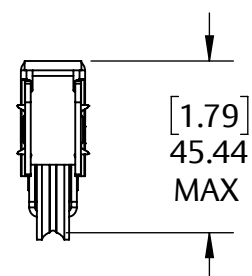
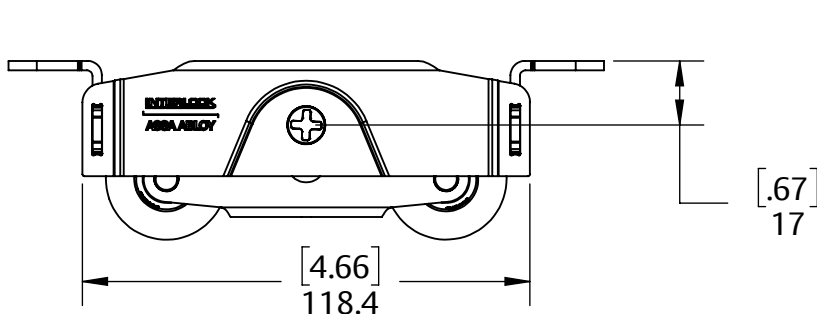

[inches]
mm

www.interlockna.com
877.852.8808

INTERLOCK™
ASSA ABLOY

RENNA™ 450

Snap-In Mounting Tabs

ASSA ABLOY

assaabloy.com

Experience a safer
and more open world



Snap-In

Part Code	Case & Carrier Material	Wheel Material	Adjustment Range	Box Quantity
PR05-0100	Stainless	Stainless	0.36"	40
PR05-0110	Steel	Steel	0.36"	40
PR05-0116	Steel	Composite	0.36"	40

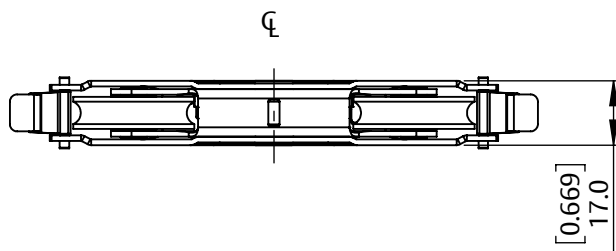
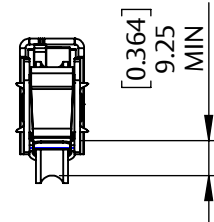
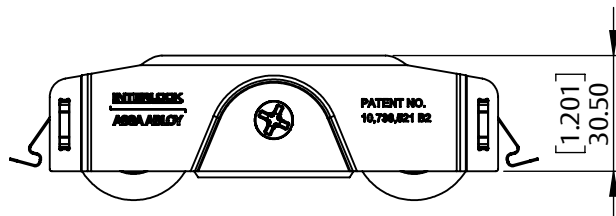
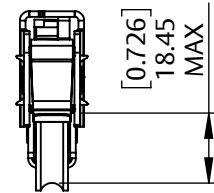
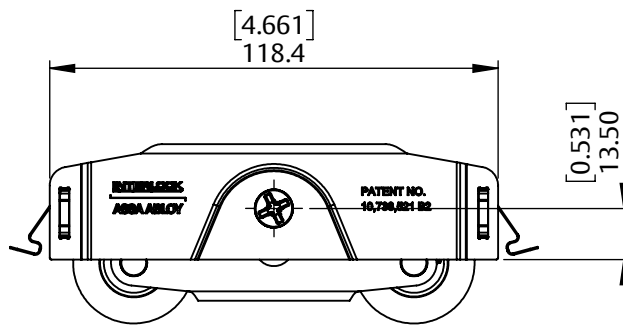

[inches]
mm

www.interlockna.com
877.852.8808

INTERLOCK™
ASSA ABLOY