

REV.#	DESCRIPTION	DATE	APPRV
4	Redrawn to SolidWorks. MAXIMUM EXTENDED LENGTH was = (BALANCE No. x 2) - .625	8/12/05	RML
5	Removed ALL reference to Balance Product Version Level. Added Note/Watermark to Reference 99A82.	10/24/07	ASJ
6	Removed weight chart	5/30/12	MBT

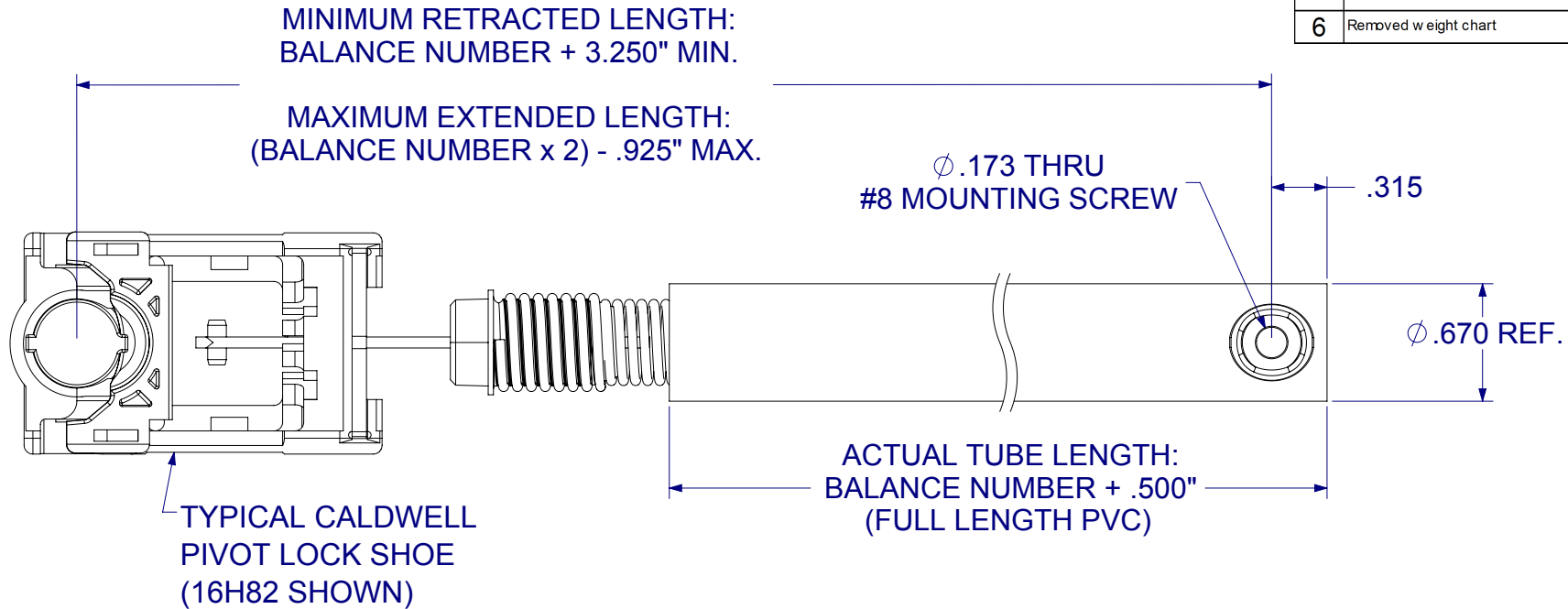

RECOMMENDED APPLICATION RANGES

THE VALUES SHOWN CONTAIN A DEGREE OF BALANCE TRAVEL PROTECTION. THEY ARE APPROPRIATE FOR USE IN COMMERCIAL APPLICATIONS.

MATERIAL/TREATMENT/FINISH:

NOTE: DO NOT SCALE DRAWING!
UNLESS OTHERWISE SPECIFIED ALL TOLERANCES ARE AS FOLLOWS:

INCHES

TWO DECIMAL PLACES	± .010
THREE DECIMAL PLACES	± .005
ANGULAR	± 1°
FRACTIONS	± 1/64

DIMENSION IDENTIFICATION SYMBOLS

- ⬡ = LOW / MEDIUM CRITICALITY
 - ⬢^{CTF} = CRITICAL TO FUNCTION
 - ⬢^{CTP} = CRITICAL TO PROCESS
 - ⬢^{SPC} = STATISTICAL PROCESS CONTROL
- LAST # USED = **XX**

THIS IS THE PROPERTY OF
CALDWELL MFG. CO.
ANY USE OR REPRODUCTION
WITHOUT AUTHORIZATION BY
THIS COMPANY IS PROHIBITED.

<i>Solutions That Set New Standards</i> CALDWELL <small>Since 1888</small>		
Manufacturing Company 2605 Manitou Road, Rochester, New York		
TITLE (ULTRA-LIFT / TILT CARRIERS) UL TRAVEL CHARACTERISTICS		
THIRD ANGLE PROJECTION	DRAWN RML	DATE 08/12/05
	CHECKED _____	DATE _____
APPROVED ASJ	DATE 06/07/12	REV _____
EX NO _____	DWG NO SL-14A-002	REV 6
SIZE _____	SHEET 1 OF 1	SCALE 1:4