

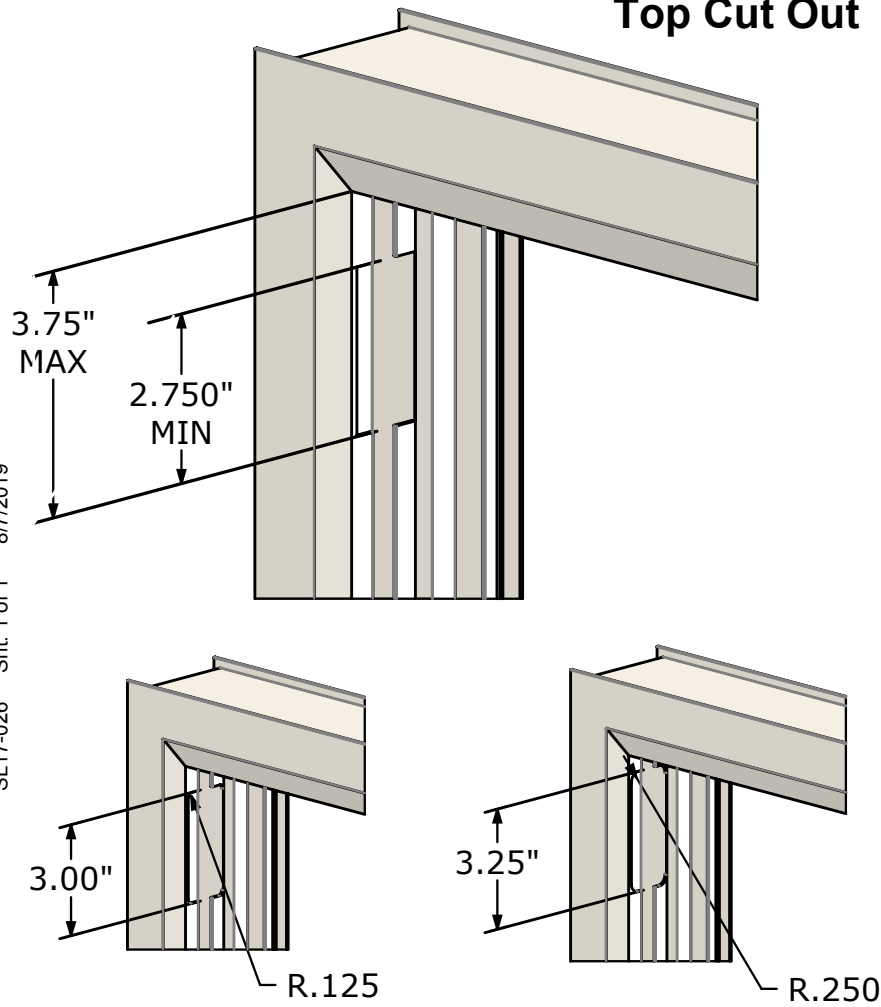

Jamb Cut Out Specifications

For ROLLER TILT® ELITE™ 562, 625, and 880

Top Cut Out



Maximum length of 3.75" for both the cut out and space above the cut out.

For radiused corners please note the change in cut out size.

1/8" radius corner, cut out must be .25" added to the overall length (.3.0")

1/4" radius corner, cut out must be .50" added to the overall length (.3.25")

Bottom Cut Out

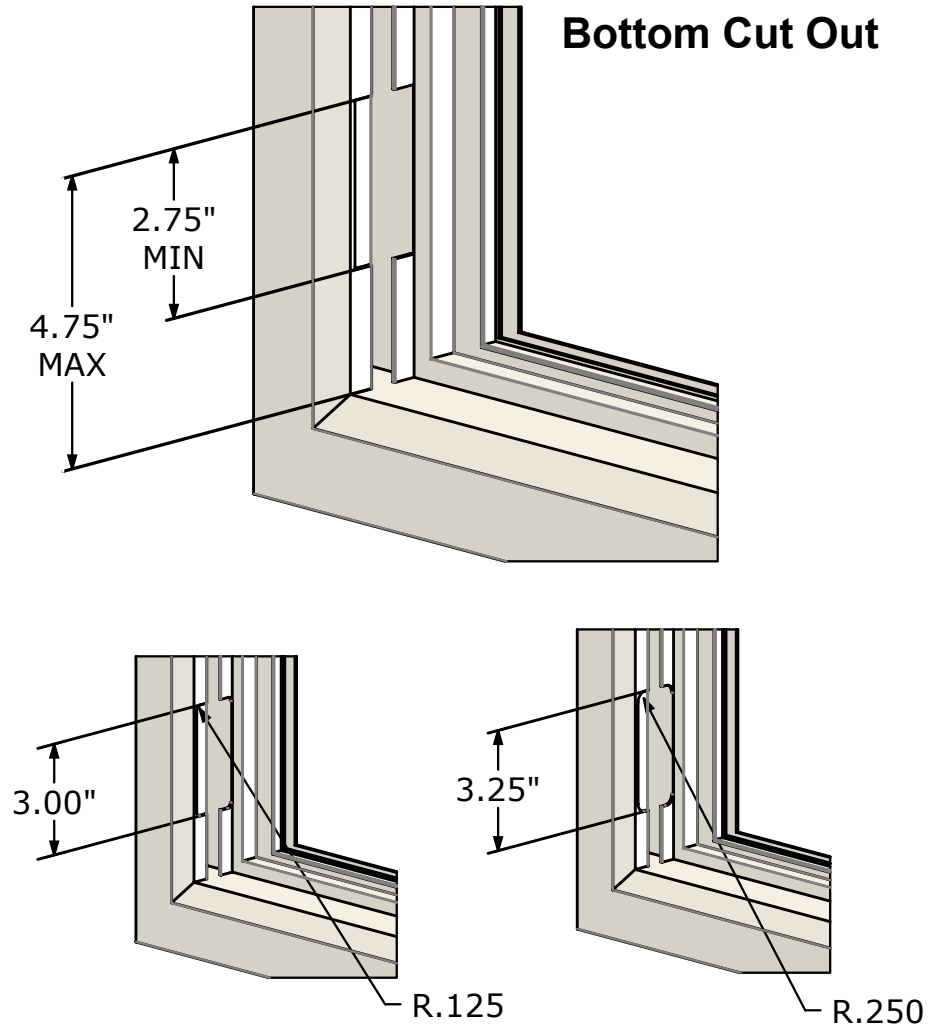

Maximum length of 4.75" for both the cut out and space below the cut out.

For radiused corners please note the change in cut out size.

1/8" radius corner, cut out must be .25" added to the overall length (.3.0")

1/4" radius corner, cut out must be .50" added to the overall length (.3.25")

SL17-026 Sht. 1 of 1 8/7/2019