

Series 77t Positive Lock - Sash Installation

(Carrier/Pivot Bar Engagement)

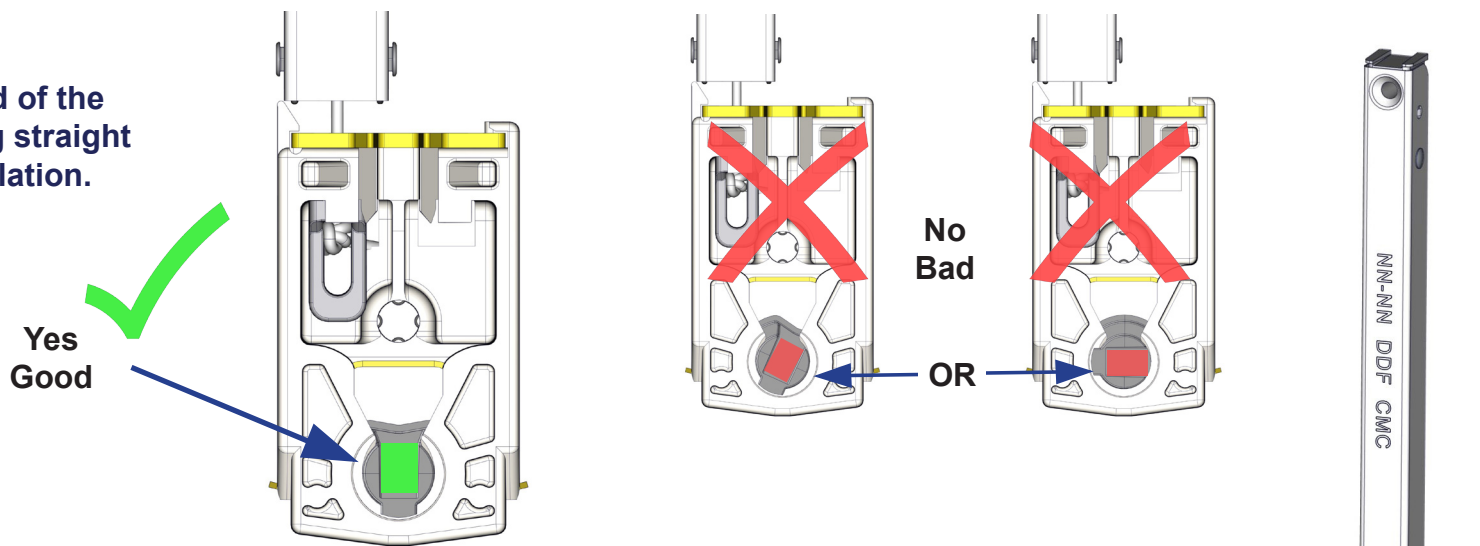

Step 1:
Confirm the open end of the metal cam is pointing straight up before sash installation.



Step 2:
Insert the head of the pivot bars (both sides of the sash) down into the open end of the metal cams. Hold the sash at a 90 degree angle to the frame as shown. Level the position of the locking shoes if needed.

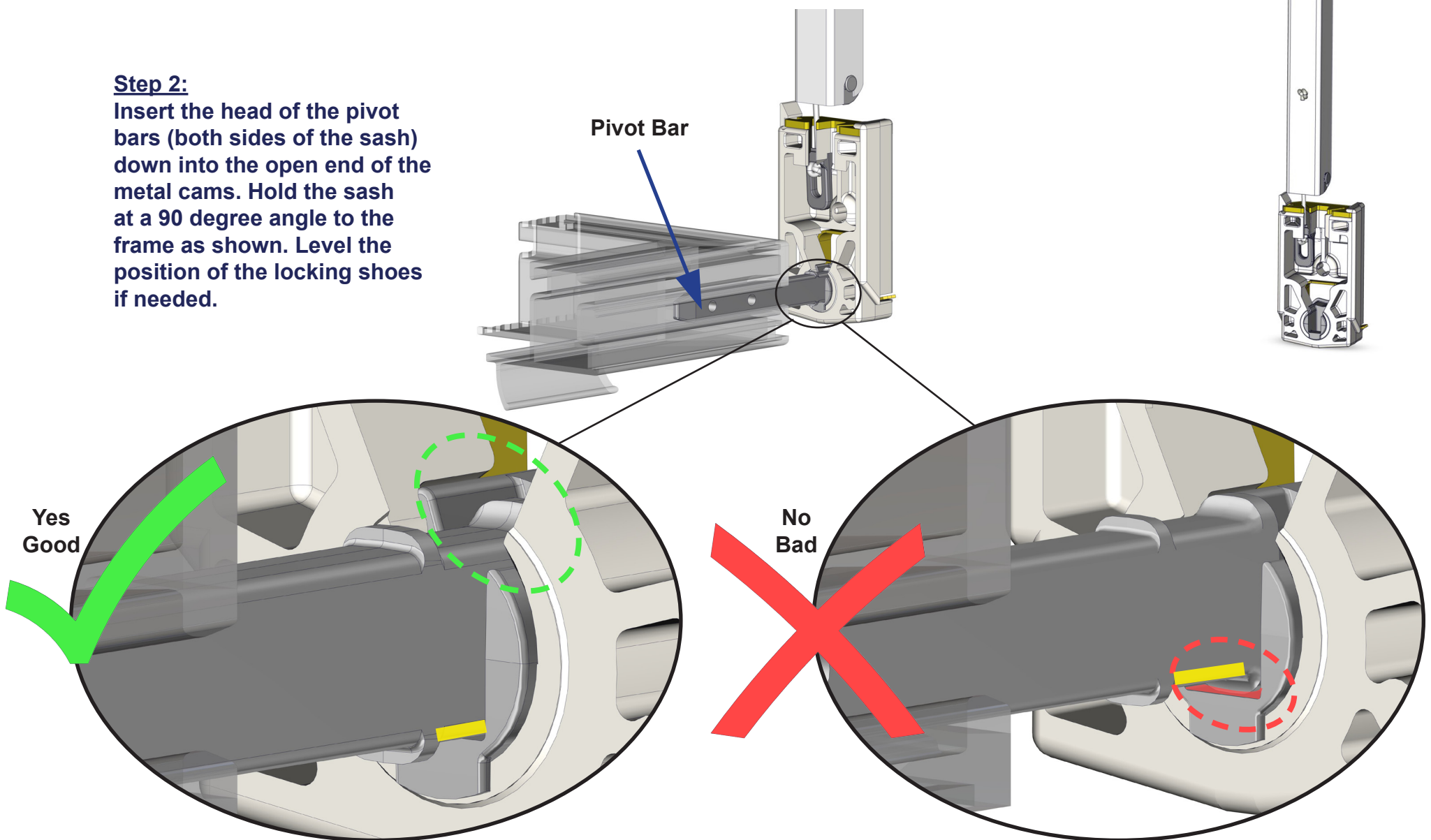

Make sure the section of the pivot bar highlighted in yellow is fully down within the metal cam. The T head nubs of the pivot bar must be beyond the front lip of the metal cam on both sides of the sash.

Do NOT allow the pivot bar on either side of the sash to be partially inserted and raised out of the metal cam when tilting the sash back into position. This can result in loss of window function.

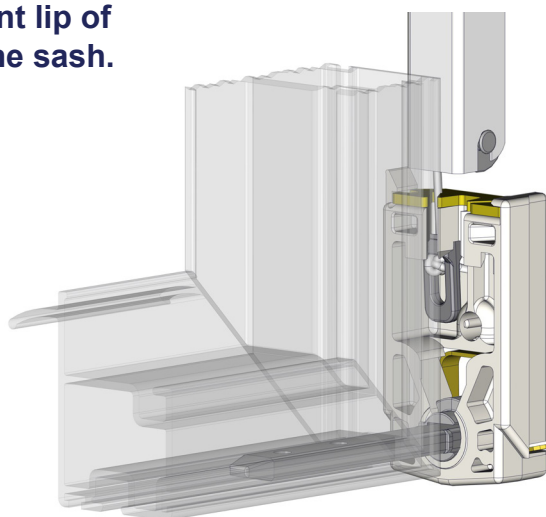

Step 3:
After the previous steps are complete, and the sash is level across the frame opening (step 2) rotate (tilt) the sash back into the upright normal operating position. Insure that the tilt latches on the top corners of the sash (not shown) are snapped fully back into the engaged position. Sash installation is now complete.