

MAGNUM® Hinges

5500/5800 Series 4-Bar Channel Mount Projection Hinges

CALDWELL

ASSA ABLOY

TYPE 1 Eurogroove with .025 offset
5500 Series Hinges (Groove A)

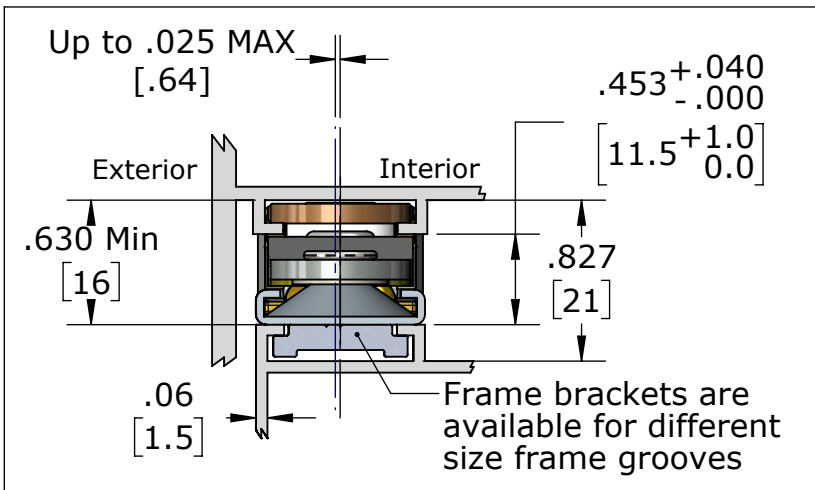

TYPE 1 Eurogroove with .040 offset
5800 Series Hinges (Groove B)

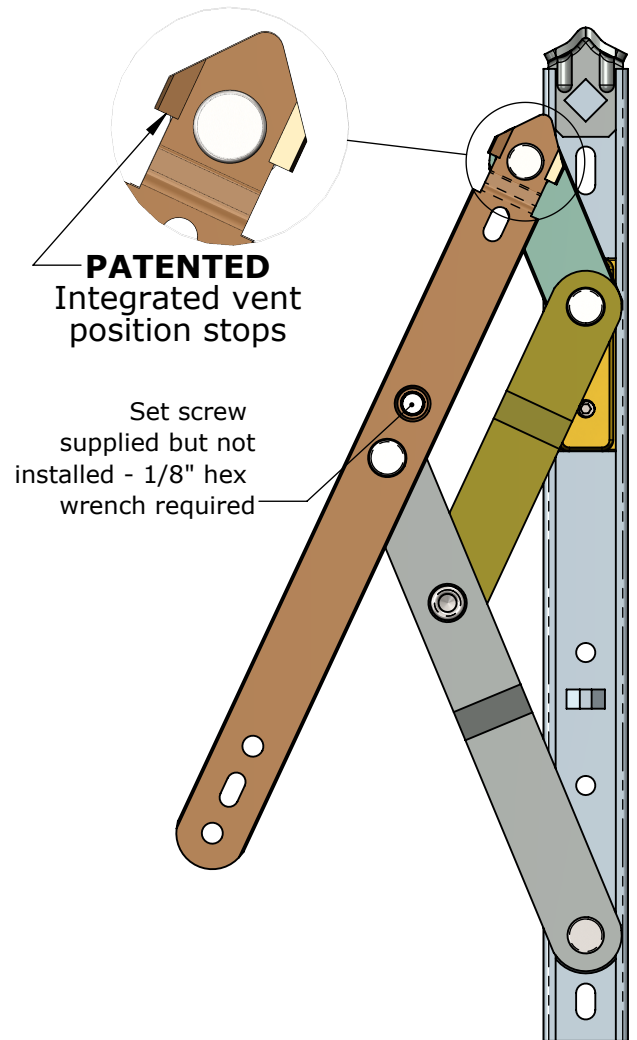
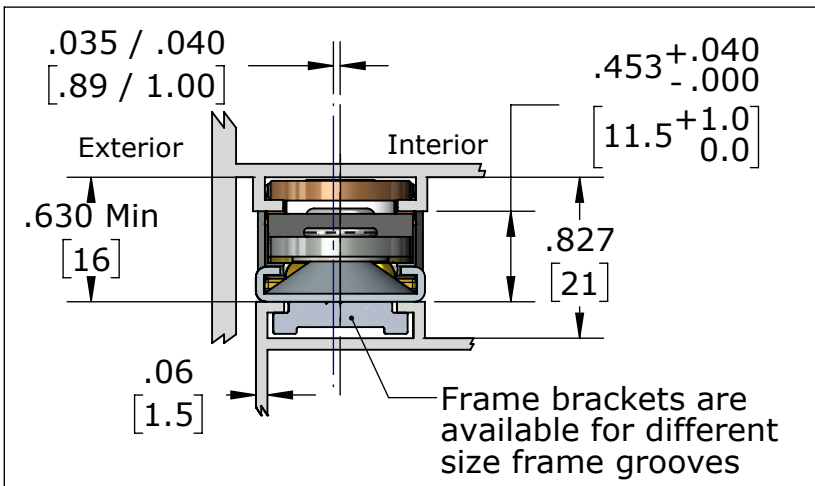

See 2000 Series
inline hinge for
hole locations

PART #	Groove	Size	Vent Height	Vent Weight	Max Opening
55-210 58-210	A B	10" [254]	11 - 28 [280 - 711]	88 lbs [40 kg]	60°
55-216 58-216	A B	16" [406]	28 - 40 [711 - 1016]	125 lbs [56.7 kg]	49°
55-224 58-224	A B	24" [610]	40 - 60 [1016 - 1524]	180 lbs [81.8 kg]	30° 45° w/o Stop

Tensions Available: Architectural and Loose rivet.

Hinge Mounting: Use #10 or M5 stainless steel pan head screws.

Hinge Capacity: Vent size and weight should not exceed the stated capacity of the hinge.

Opening Degree: For vents in high winds, severely limited opening or limited for life safety, the use of additional Limit/Friction Devices may be required (ex: 177, 419, 716).