

# MAGNUM™ Hinges (Casement Egress Hinge #5012)

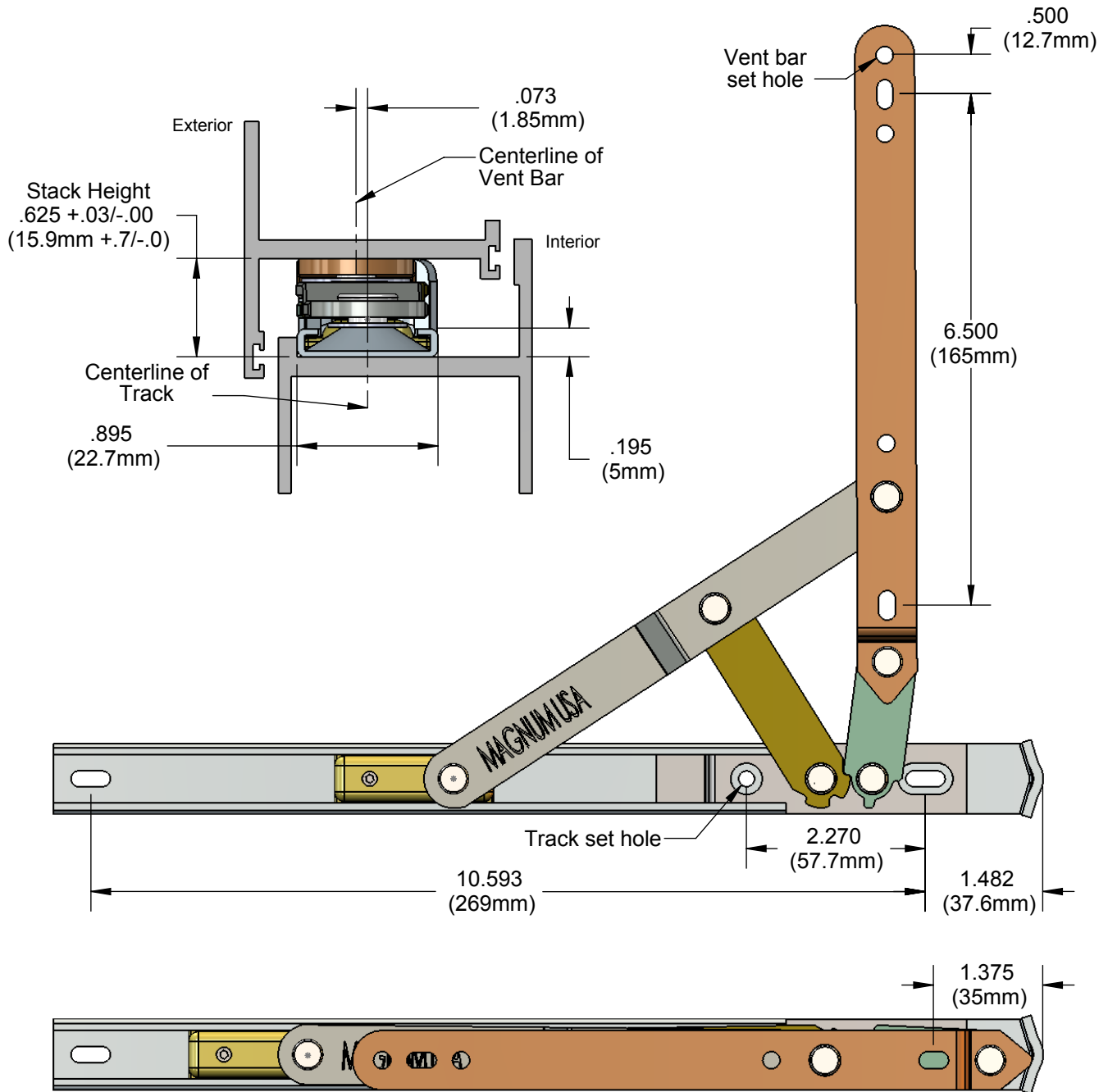

A020 cat12 5012 hinges\_r1; date 4/22/2015

Part#	Size	Vent Width	Vent Weight	Max Opening
5012	12" (305mm)	13.0 - 36.0 (330mm-914mm)	160 lbs (72.6 kg)	90°

Tensions Available: Commercial and loose rivet.  
 Hinge Mounting: Use #10 or M5 stainless steel pan head screws.  
 Hinge Capacity: Vent size and weight should not exceed the stated capacity of the hinge.