

REVISIONS

REV.#	DESCRIPTION	DATE	BY

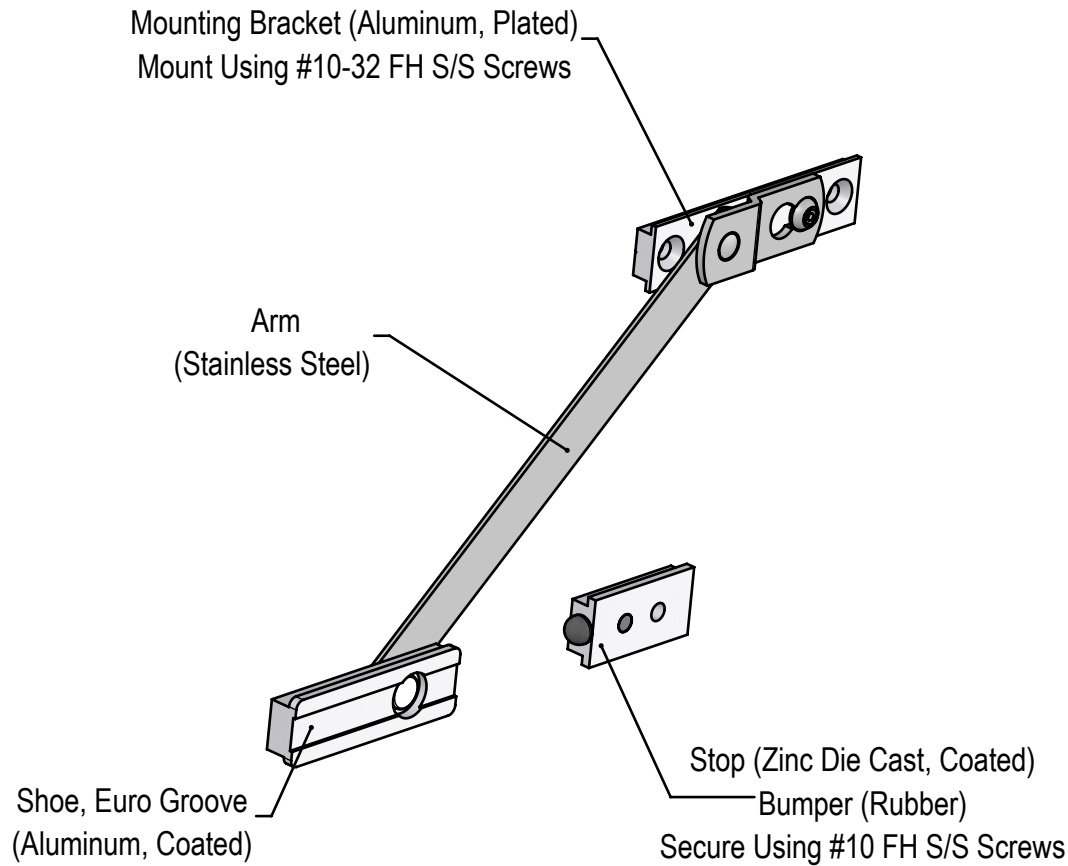

Part#	Arm Length
876-4	4 (102mm)
876-5	5 (127mm)
876-6	6 (152mm)
876-7	7 (178mm)
876-8	8 (203mm)
876-10	10 (254mm)
876-12	12 (305mm)

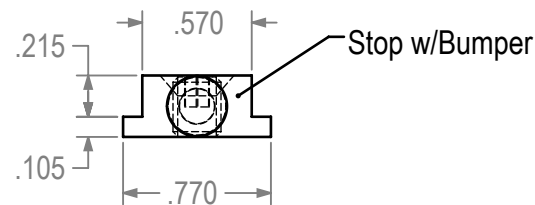
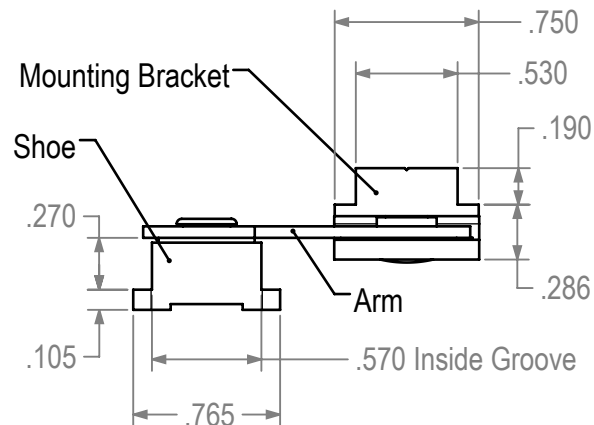

Dimensions Are For Reference Purposes Only

876 Euro Groove Keyed Limit Device

Solutions That Set New Standards
CALDWELL
 Since 1888

Manufacturing Company 2605 Manitou Road, Rochester, New York

TITLE: **876 Euro Groove Keyed Limit Device** (ADV)

THIRD ANGLE PROJECTION	DRAWN HV	DATE 1/4/16
	CHECKED	DATE
	APPROVED	DATE
A	EX NO	DWG NO
SIZE		876 twc
SCALE 1:1	SHEET 1 OF 1	REV 0