

REVISIONS			
REV.#	DESCRIPTION	DATE	BY

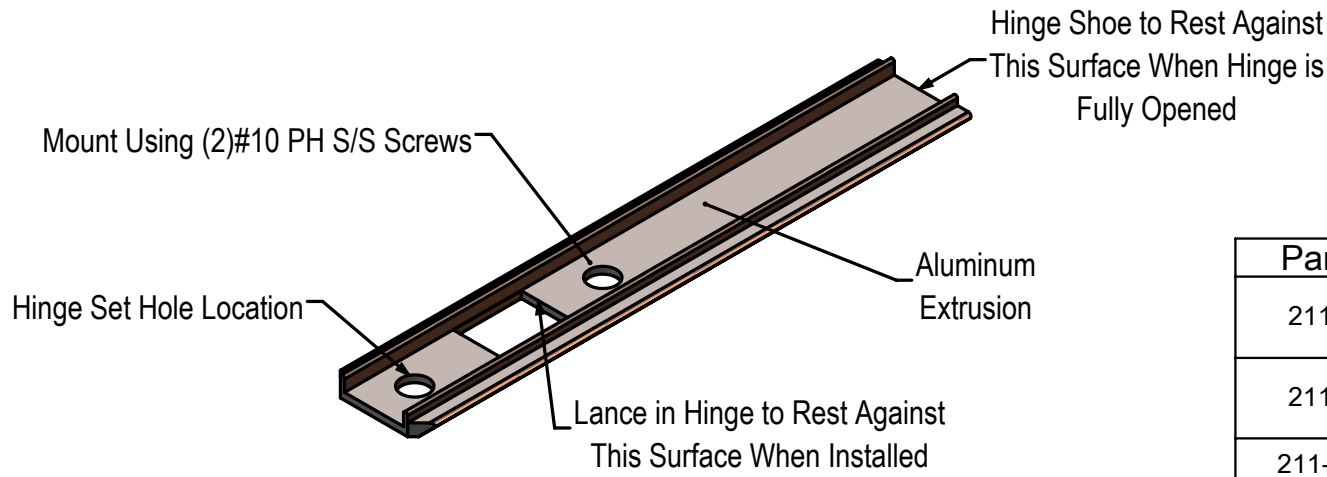

Part#	"B"	Comment
211-4	2.75(69.9mm)	12"-16" Hinges, Customer Cut to Length
211-6	5.50(139.7mm)	20"-24" Hinges, Customer Cut to Length
211-"B"	Customer Designated	See Min/Max Size Note

211-"B" In Hinge Limit Device for Projection hinges

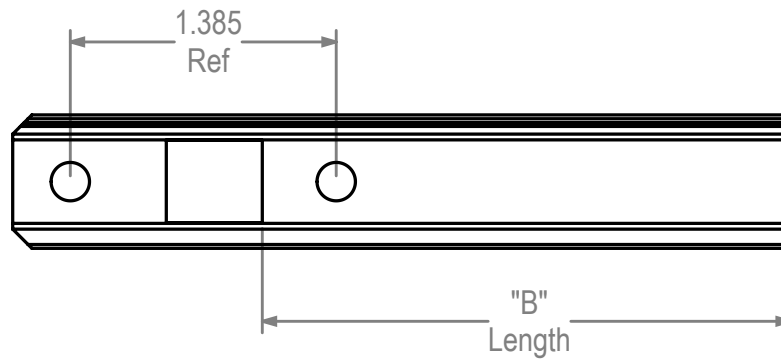

Dimensions Are For Reference Purposes Only

When ordering a special length the "B" dimension is required. Example, if "B" = 2.47" then order 211-2.47

Minimum "B" Dimension Available is 1.33"(33.8mm)
Maximum "B" Dimension Available is 5.70"(144.8mm)

Solutions That Set New Standards CALDWELL Since 1888		
Manufacturing Company 2605 Manitou Road, Rochester, New York		
TITLE 211 In Hinge Limit Device for Projection Hinges (ADV)		
THIRD ANGLE PROJECTION	DRAWN HV	DATE 8/14/14
	CHECKED	DATE
	APPROVED	DATE
A	EX NO	DWG NO
SIZE		211 twc
SCALE 1:1	SHEET 1 OF 1	REV 0