

REVISIONS			
REV.#	DESCRIPTION	DATE	BY

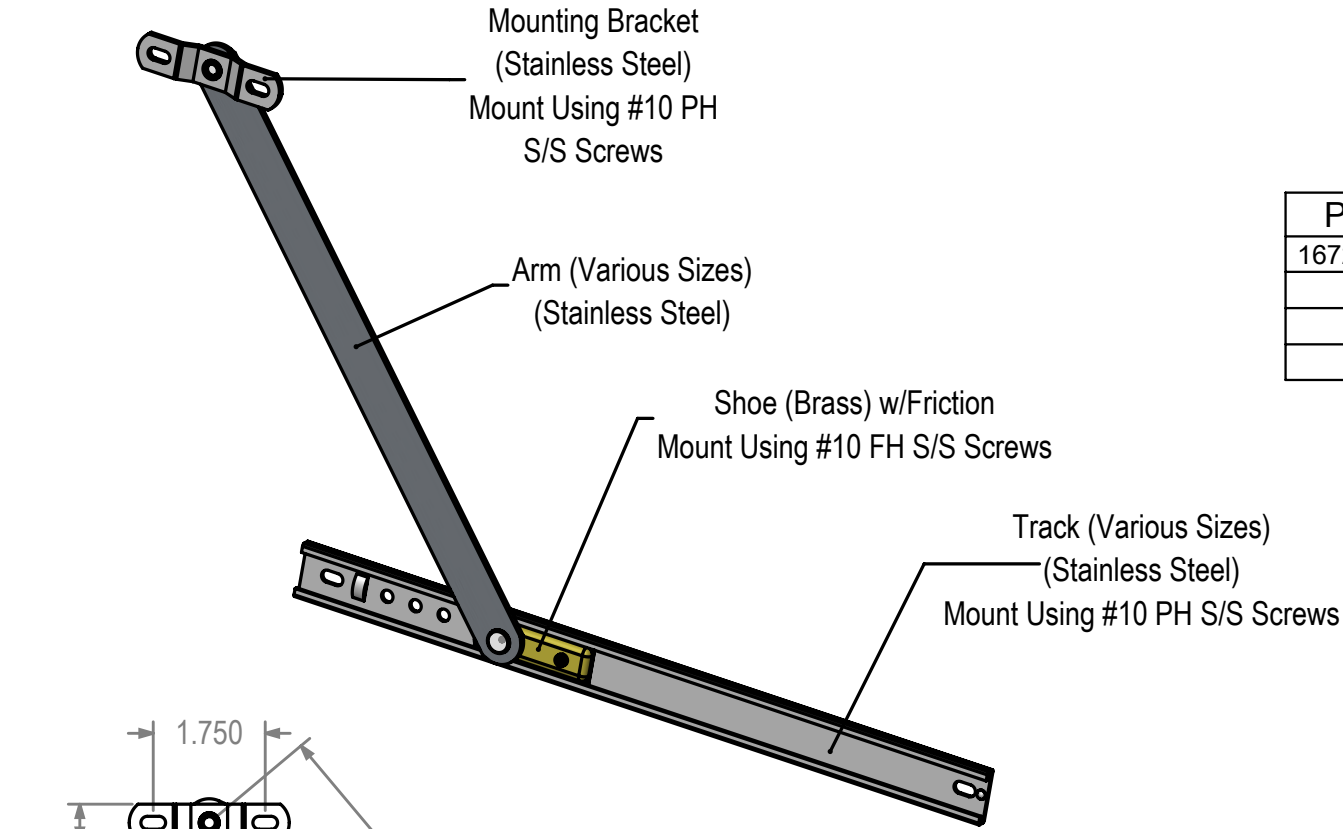

Part#	"A"	"T"
1672-10-12	10 (254mm)	12 (305mm)

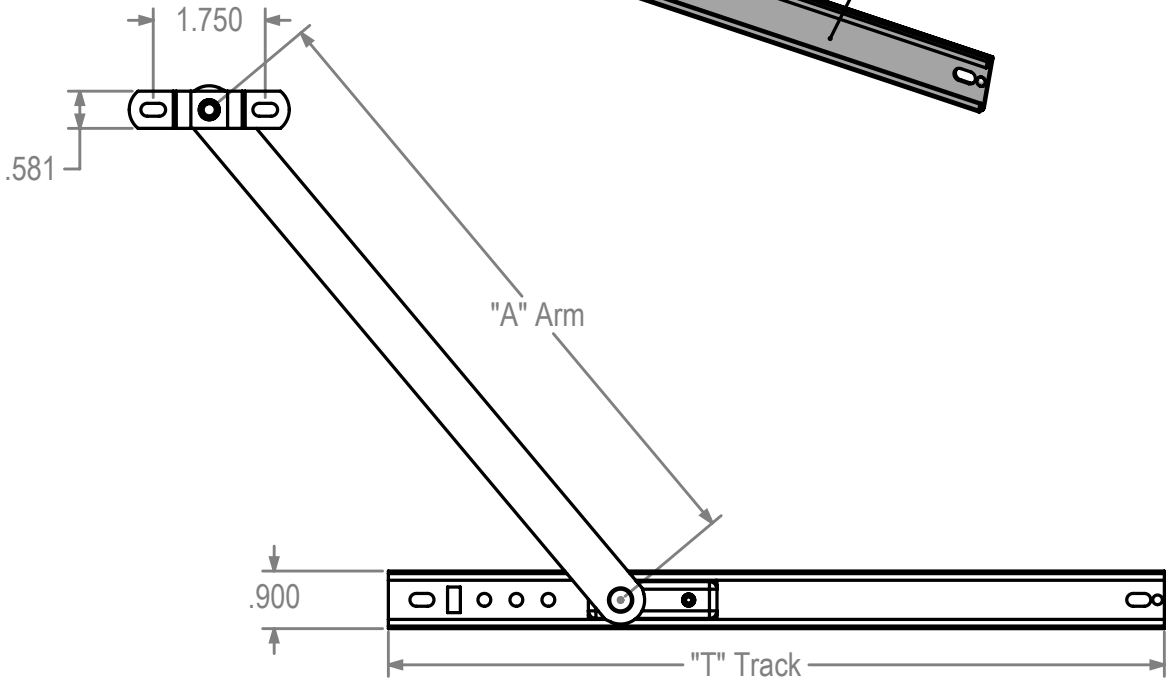

Friction Adjuster

Dimensions Are For Reference Purposes Only

Solutions That Set New Standards
CALDWELL
 Since 1888

Manufacturing Company 2605 Manitou Road, Rochester, New York

TITLE: **Friction Adjuster (Limit Device)** (ADV)

THIRD ANGLE PROJECTION	DRAWN HV	DATE 8/4/14
	CHECKED	DATE
	APPROVED	DATE

A	EX NO	DWG NO	REV
SIZE		1672 twc	0

SCALE 1:3 SHEET 1 OF 1