

REVISIONS			
REV.#	DESCRIPTION	DATE	BY

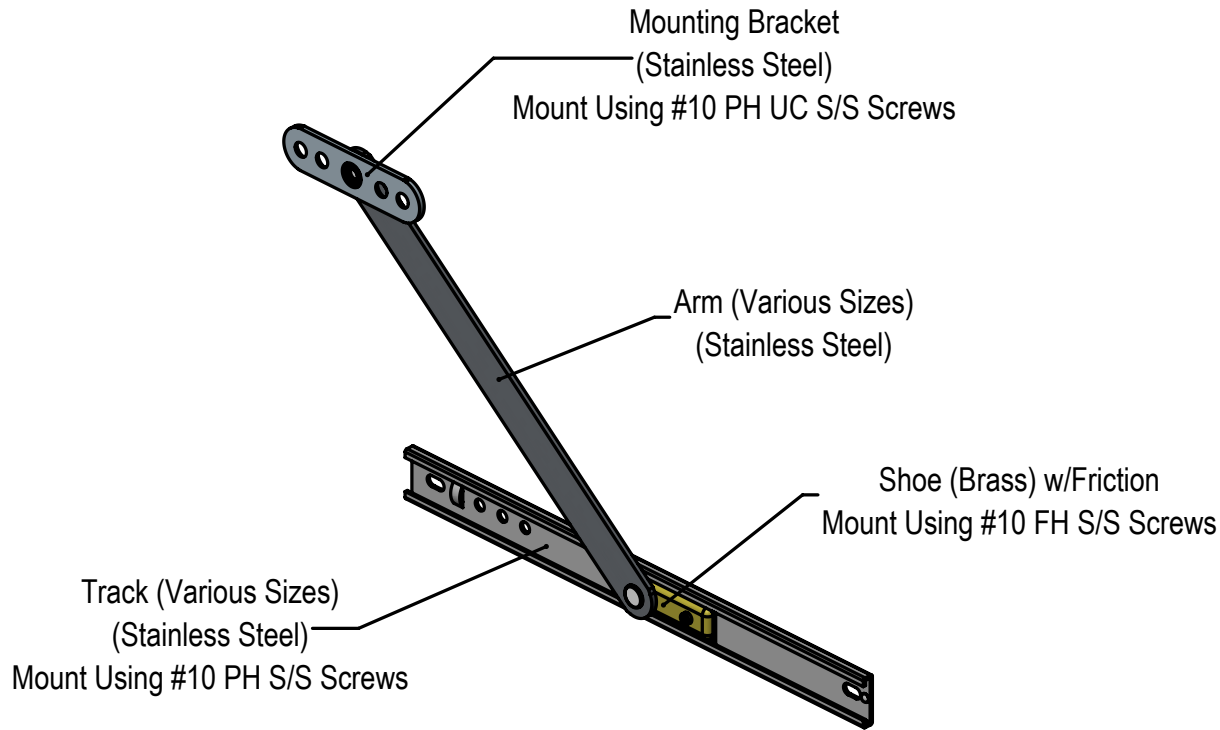

Part#	"A"	"T"
1312-8-10	8 (203mm)	12 (305mm)

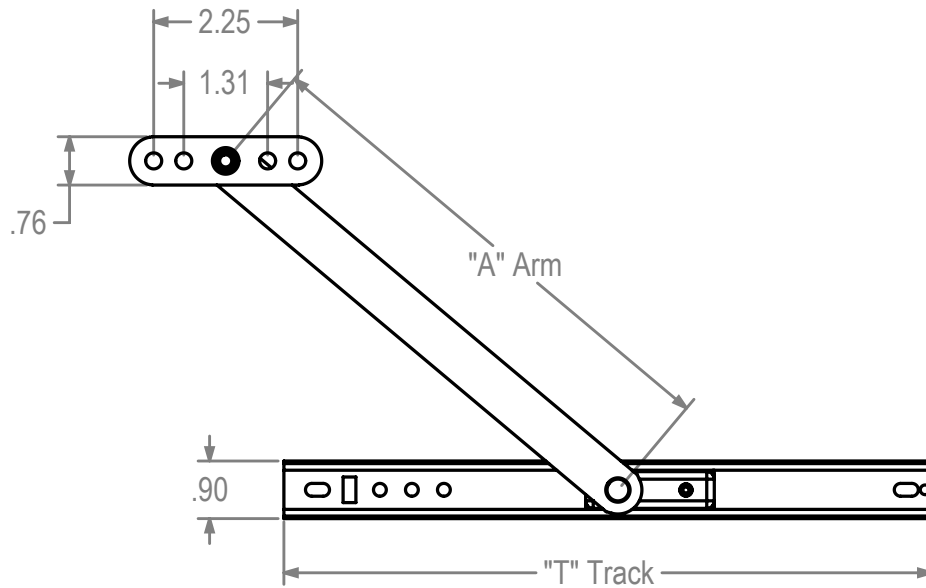

Friction Adjuster

Dimensions Are For Reference Purposes Only

Solutions That Set New Standards
CALDWELL
 Since 1888

Manufacturing Company 2605 Manitou Road, Rochester, New York

TITLE
Friction Adjuster (Limit Device) (ADV)

THIRD ANGLE PROJECTION	DRAWN HV	DATE 8/11/14
	CHECKED	DATE
	APPROVED	DATE

A	EX NO	DWG NO	REV
SIZE		1312 twc	0

SCALE 1:3 SHEET 1 OF 1